

PROHLÁŠENÍ O VLASTNOSTECH

DoP 0253

pro fischer termoz SV II ecotwist (Plastové hmoždinky pro použití do betonu a zdiva)

CS

- | | | |
|--|---|-------------------|
| 1. <u>Jedinečný identifikační kód typu výrobku:</u> | DoP 0253 | |
| 2. <u>Zamýšlené/zamýšlená použití:</u> | Šroubovací plastová kotva pro ukotvení vnějších tepelně izolačních kompozitních systémů (ETICS) s omítkou do betonu a zdiva, viz. dodatek, obzvláště Přílohy B1 - B3. | |
| 3. <u>Výrobce:</u> | fischerwerke GmbH & Co. KG, Klaus-Fischer-Str. 1, 72178 Waldachtal, Německo | |
| 4. <u>Zplnomocněný zástupce:</u> | - | |
| 5. <u>Systém/systémy POSV:</u> | 2+ | |
| 6. <u>Evropský dokument pro posuzování:</u> | EAD 330196-01-0604 | |
| Evropské technické posouzení: | ETA-12/0208; 2017-12-05 | |
| Subjekt pro technické posouzení: | DIBt- Deutsches Institut für Bautechnik | |
| Oznámený subjekt/oznámené subjekty: | 2873 TU Darmstadt | |
| 7. <u>Deklarovaná vlastnost/Deklarované vlastnosti:</u> | | |
| Bezpečnost při používání (BWR 4) | | |
| Charakteristická únosnost: | Charakteristická únosnost při zatížení tahem: | Příloze C1 |
| | Minimální okrajová vzdálenost: | Příloze B2 |
| | Minimální osová vzdálenost: | Příloze B2 |
| Posuny: | Zatížení tahem s dílčím součinitelem: | Příloze C2 |
| | Posuny: | Příloze C2 |
| Tuhost rozšiřujícího talíře: | Průměr rozšiřujícího talíře: | NPD |
| | Odolnost rozšiřujícího talíře proti zatížení: | NPD |
| | Tuhost rozšiřujícího talíře: | NPD |
| Úspora energie a retence tepla (BWR 6) | | |
| Prostup tepla: | Bodový činitel prostupu tepla kotvy: | Příloze C2 |
| | Tloušťka izolační vrstvy ETICS: | Příloze C2 |
| 8. <u>Příslušná technická dokumentace a/nebo specifická technická dokumentace:</u> | - | |

Vlastnosti výše uvedeného výrobku jsou ve shodě se souborem deklarovaných vlastností. Toto prohlášení o vlastnostech se v souladu s nařízením (EU) č. 305/2011 vydává na výhradní odpovědnost výrobce uvedeného výše.

Podepsáno za výrobce a jeho jménem:



Dr.-Ing. Oliver Geibig, Výkonný ředitel pro obchodní jednotky a inženýrství
Tumlingen, 2021-01-15



Jürgen Grün, Výkonný ředitel pro chemii a kvalitu

Toto PoV bylo připraveno v různých jazykových mutacích. V případě rozporu vždy rozhoduje interpretace verze v anglickém jazyce.

Příloha obsahuje nepovinné a doplňkové informace v anglickém jazyce nad rámec zákonných požadavků.

Specific Part

1 Technical description of the product

The fischer termoz SV II ecotwist screwed-in anchor consist of an anchor sleeve and a screw plate in different colours, both made of polyamide (virgin material) and an accompanying specific screw of galvanised steel.

The product description is given in Annex A.

2 Specification of the intended use in accordance with the applicable European Assessment Document

The performances given in Section 3 are only valid if the anchor is used in compliance with the specifications and conditions given in Annex B.

The verification and assessment methods on which this European Technical Assessment is based lead to the assumption of a working life of the anchor of at least 25 years. The indications given on the working life cannot be interpreted as a guarantee given by the producer, but are to be regarded only as a means for choosing the right products in relation to the expected economically reasonable working life of the works.

3 Performance of the product and references to the methods used for its assessment

3.1 Mechanical resistance and stability (BWR 1)

Essential characteristic	Performance
Characteristic tension resistance	See Annex C1
Edge distances and spacing	See Annex B2
Displacements	See Annex C2

3.2 Energy economy and heat retention (BWR 6)

Essential characteristic	Performance
Point thermal transmittance	See Annex C2

4 Assessment and verification of constancy of performance (AVCP) system applied, with reference to its legal base

In accordance with EAD No. 330335-00-0604, the applicable European legal act is: [97/463/EC].

The system to be applied is: 2+

Installed anchor : termoz SV II ecotwist

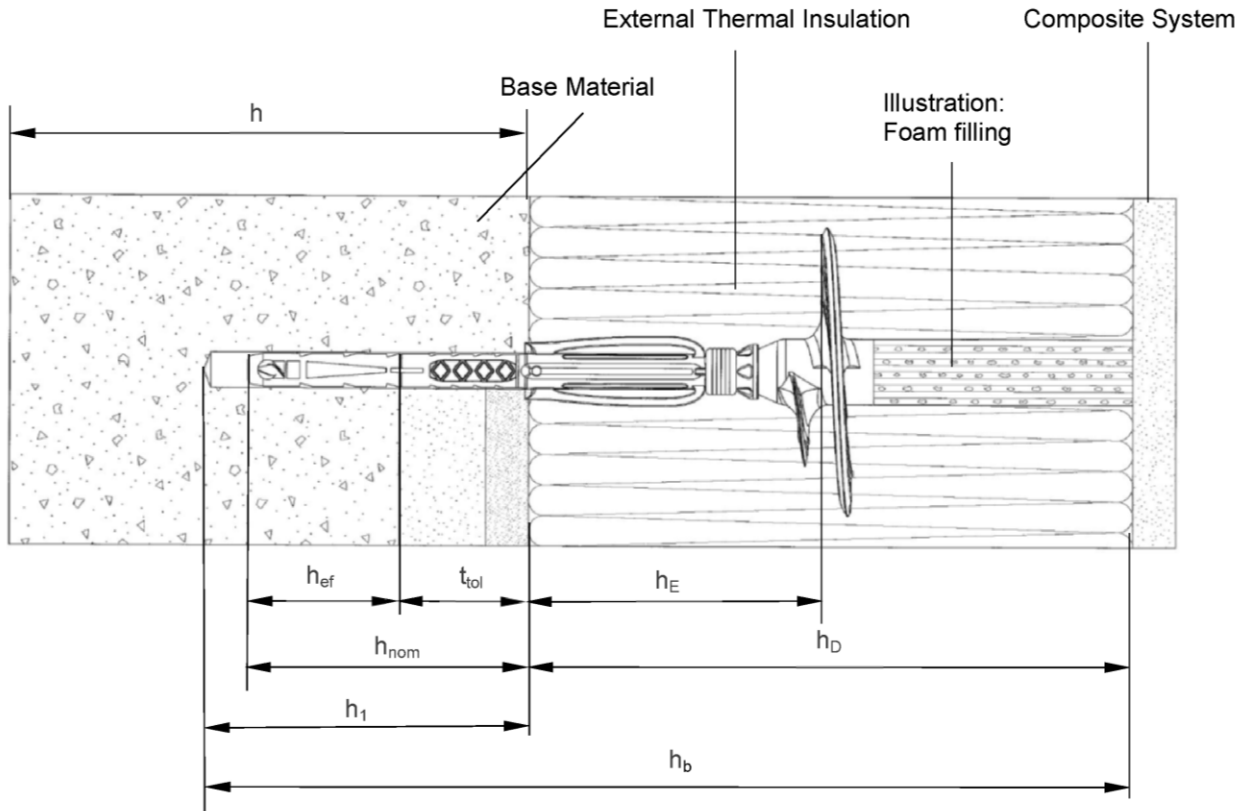

Legend

- h_{nom} = Overall plastic anchor embedment depth in the base material with non-load bearing coating (t_{tol})
- h_1 = Depth of drilled hole to deepest point in the base material
- h = Thickness of base material (wall)
- h_D = Thickness of insulation material
- t_{tol} = Thickness of equalizing layer and / or non-load bearing coating
- h_E = Embedment depth
- h_b = Total bore hole depth
- h_{ef} = Effective anchor embedment depth in the base material

Figures not to scale.

fischer termoz SV II ecotwist

Product description
Installed anchor

Annex A1

Appendix 2 / 9

Parts: termoz SV II ecotwist

Anchor sleeve

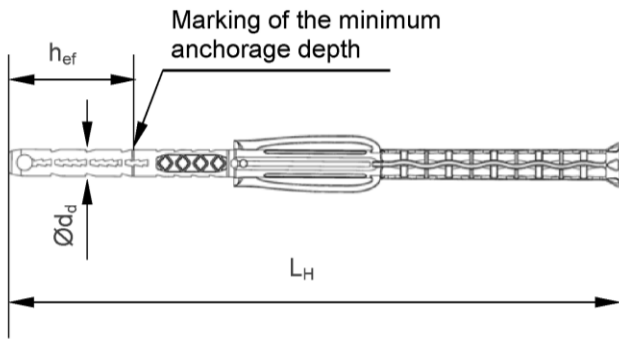

Screw plate

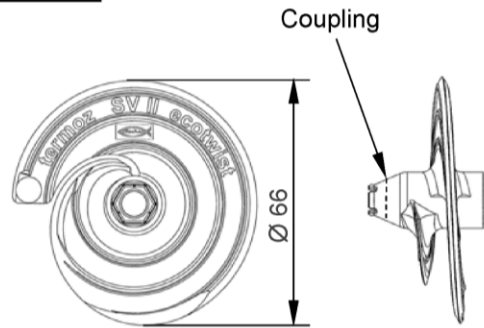

Special screw

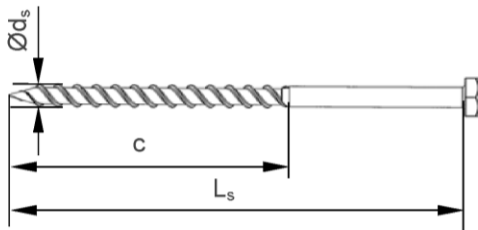

Adjustment of the ring depends of the insulation material thickness, e.g. $h_D = 180$ mm
 → adjust value 180 at the setting tool

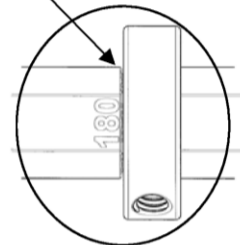

Setting tool

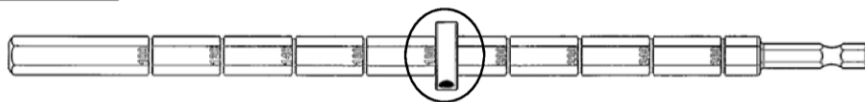

Anchor complete

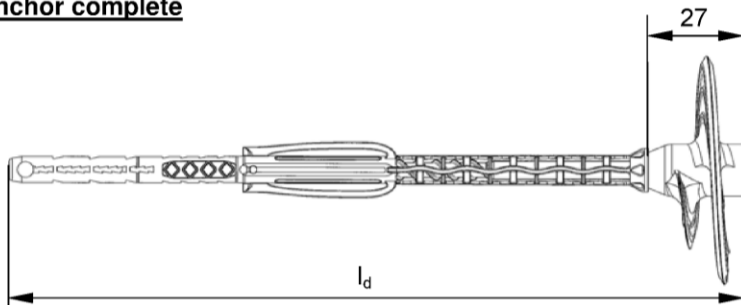

Figures not to scale.

fischer termoz SV II ecotwist

Product description
 Anchor type and parts

Annex A2

Appendix 3 / 9

Table A3.1: Dimensions								
Anchor type	Anchor sleeve					Special screw		
termoz SV II ecotwist	$\varnothing d_d$	$h_{ef}^{1)}$	$h_E^{1)}$	l_d	L_H	$\varnothing d_s$	L_s	c
	[mm]							
t_{tol} 0-10 mm	8	35	70	162	135	6	100	74
t_{tol} 0-30 mm				202	175		120	
t_{tol} 30-60 mm				232	205		150	

¹⁾ see Annex A1

Table A3.2: Marking on the plate





	Marking
Anchor type	termoz SV II ecotwist
Works symbol	 or 
Example	fischer (optional) termoz SV II ecotwist  or  CE (optional);  Ø 8 (optional); ABCDE (optional) XXXXX= various additional markings allowed

Table A3.3: Marking on the anchor sleeve

	Marking
termoz SV II ecotwist t_{tol} 0-10 mm	t_{tol} 0-10
termoz SV II ecotwist t_{tol} 0-30 mm	t_{tol} 0-30
termoz SV II ecotwist t_{tol} 30-60 mm	t_{tol} 30-60

Table A3.4: Material

Designation	Material
Anchor sleeve	PA6 (virgin material), colour: grey
Screw plate	PA6 (virgin material) GF, colour: grey, yellow, red, orange, green, blue
Special screw	Steel; gal Zn A2G or A2F according to EN ISO 4042:1999

fischer termoz SV II ecotwist

Product description

Anchor types, marking on the anchor plate/sleeve, dimensions and material

Annex A3

Appendix 4 / 9

Specifications of intended use

Anchorage subject to:

- The anchor may only be used for transmission of wind suction loads and shall not be used for the transmission of dead loads of the external thermal insulation composite system (ETICS).

Base materials:

- Normal weight concrete (use category A), according to Annex C1
- Solid masonry (use category B), according to Annex C1
- Hollow or perforated masonry (use category C), according to Annex C1
- Lightweight aggregate concrete (use category D), according to Annex C1
- Autoclaved aerated concrete (use category E), according to Annex C1
- For other base materials of the use categories A, B, C, D and E the characteristic resistance of the anchor may be determined by job site tests acc. to EOTA Technical Report TR 051 Edition December 2016.

Temperature Range:

- 0°C to +40°C (max. short term temperature +40°C and max. long term temperature +24°C)

Design:

- The anchorages are designed under the responsibility of an engineer experienced in anchorages and masonry work with the partial safety factors $\gamma_M = 2,0$ and $\gamma_F = 1,5$ in absence of other national regulations.
- Verifiable calculation notes and drawings are prepared taking account of the loads to be anchored. The position of the anchors is indicated on the design drawings.
- Fasteners are only to be used for multiple fixings of ETICS.

Installation:

- Drill method according to Annex C1
- Anchor installation carried out by appropriately qualified personnel and under the supervision of the person responsible for technical matters on the site
- Installation temperature from 0°C to +40°C
- Exposure to UV due to solar radiation of the anchor not protected by rendering ≤ 6 weeks

fischer termoz SV II ecotwist

Intended use
Specifications

Annex B1

Appendix 5 / 9

Table B2.1: Installation parameters			termoz SV II ecotwist
Drill hole diameter	d_0	=	8
Cutting diameter of drill bit	d_{cut}	\leq	8,45
Depth of drill hole to deepest point	h_1	\geq	55/75/105
Total bore hole depth at SV II ecotwist t_{tol} 0-10 mm			$h_D + 55$
Total bore hole depth at SV II ecotwist t_{tol} 0-30 mm	h_b	\geq	$h_D + 75$
Total bore hole depth at SV II ecotwist t_{tol} 30-60 mm			$h_D + 105$
Overall plastic anchor embedment depth in the base material (see Annex A1) at SV II ecotwist t_{tol} 0-10 mm			45
Overall plastic anchor embedment depth in the base material (see Annex A1) at SV II ecotwist t_{tol} 0-30 mm	h_{nom}	=	65
Overall plastic anchor embedment depth in the base material (see Annex A1) at SV II ecotwist t_{tol} 30-60 mm			95

Table B2.2: Minimum distances and dimensions			termoz SV II ecotwist
Minimum thickness of member	h_{min}		100 ¹⁾
Minimum allowable spacing	s_{min}	= [mm]	100
Minimum allowable edge distance	c_{min}		100

¹⁾ For weather resistant external wall panels: $h_{min}=40$ mm

Scheme of distances and spacing

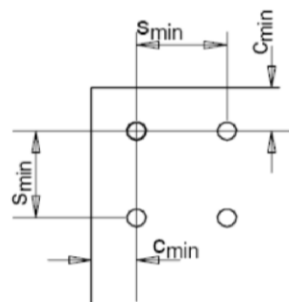

fischer termoz SV II ecotwist	Annex B2 Appendix 6 / 9
Intended use Installation parameters Minimum thickness of member, distances and spacing	

Installation instructions

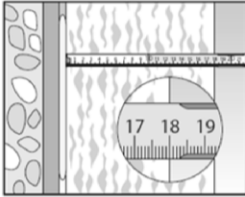

1. Measure insulation thickness h_D
(example: 18 cm = 180 mm).

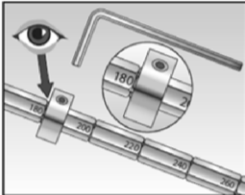

2. Adjust the setting tool ring corresponding to the insulation material thickness h_D in mm.
Number is legible.
Additionally to the setting tool ring a thin plastic plate (maximum 1 mm thickness) can be used as a stop unit for easier mounting.

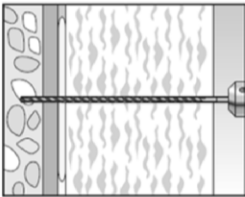

3. Drill bore hole.
Total drill hole depth must be at
 t_{tol} 0-10 mm $\rightarrow h_D + 55$ mm
 t_{tol} 0-30 mm $\rightarrow h_D + 75$ mm
 t_{tol} 30-60 mm $\rightarrow h_D + 105$ mm.
Note: Hlz, AAC only with rotary drilling

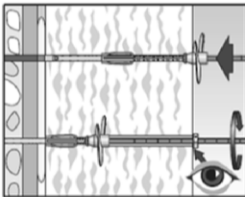

4. Press the anchor with the screw plate tight against the surface of the insulation material, then start screwing-in the anchor. Setting is finished when the surface of the ring is flush with the surface of the insulation material.

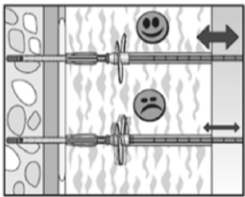

5. When step 4 is completed, press the adjustment tool tight against the installed anchor.
If there is no axial movement of the anchor, remove the setting tool.
In case of axial movement, a new anchor has to be set in a new drill hole.

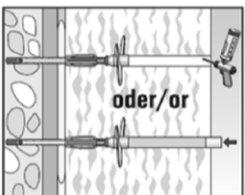

5. The hole in the insulation material must be filled with a suitable foam (illustrated in Annex A1) or must be closed with an appropriate insulation cylinder.

fischer termoz SV II ecotwist

Intended use
Installation instructions

Annex B3

Appendix 7 / 9

Table C1.1: Characteristic resistance N_{Rk}

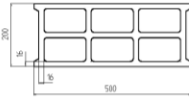
Base material	Use cat. 1)	Bulk density ρ [kg/dm ³]	Minimum compressive strength f_b [N/mm ²]	Remarks	Drill method 2)	Characteristic resistance N_{Rk} [kN]
Weather resistant skin of external wall panels, concrete C20/25 – C50/60	-	-	-	Thickness of concrete panels 40 mm ≤ h < 100 mm	H	0,9
Weather resistant skin of external wall panels, concrete C20/25 –C50/60	-	-	-	Thickness of concrete panels 40 mm ≤ h < 100 mm	R	1,5
Concrete C12/15- C 50/60 acc. to EN 206-1:2000	A	-	-	-	H	1,5
Sand-lime solid bricks, KS acc. to EN 771-2:2011	B	≥ 2,0	20	Cross section reduced up to 15% by perforation vertically to the resting area	H	1,5
			12			1,2
Clay bricks, Mz acc. to EN 771-1:2011	B	≥ 1,8	12	Cross section reduced up to 15% by perforation vertically to the resting area	H	1,2
Solid concrete block, Vbn acc. to EN 771-3:2011	B	≥ 2,0	20	Cross section reduced up to 10% by perforation vertically to the resting area	H	1,5
			12			1,2
Lightweight concrete solid blocks, Vbl acc. to EN 771-3:2011	B	≥ 1,4	8	Cross section reduced up to 15% by perforation vertically to the resting area, exterior web thickness ≥ 35 mm	H	0,6
Vertically perforated sand-lime bricks, KSL acc. to EN 771-2:2011	C	≥ 1,4	20	Cross section reduced more than 15% by perforation vertically to the resting area, Exterior web thickness ≥ 23 mm	H	1,2
			12			0,75
Vertically perforated clay bricks, Hlz acc. to EN 771-1:2011	C	≥ 1,0	12	Cross section reduced more than 15% and less than 50% by perforation vertically to the resting area, Exterior web thickness ≥ 12 mm	R	0,75
Lightweight concrete hollow blocks, Hbl acc. to EN 771-3:2011	C	≥ 1,2	10	Cross section reduced between 15% and 50% by perforation vertically to the resting area. Exterior web thickness ≥ 38 mm	H	1,2
			8			0,9
			6			0,75
			4			0,6
Lightweight concrete hollow blocks, Hbl4 acc. to EN 771-3:2011	C	≥ 0,9	4		H	0,5
Lightweight aggregate concrete, LAC acc. to EN 1520:2011 / EN 771-3:2011	D	≥ 0,9	6	-	H	0,75
Autoclaved aerated concrete blocks AAc acc. to EN 771-4:2011	E	≥ 0,5	4	-	R	0,4

1) See Annex B1

2) R = Rotary drilling | H = Hammer drilling

Figures not to scale.

fischer termoz SV II ecotwist

Performance
Characteristic resistance

Annex C1

Appendix 8 / 9

Table C2.1: Point thermal transmittance acc. to EOTA Technical TR 025 : 2016 – 05

Anchor type	Thickness of insulation material h_D [mm]	Point thermal transmittance χ [W/K]
fischer termoz SV II ecotwist EPS-plug and air void $t_{tol} = 0 - 10$ mm	100 - 240	0,001
	> 240	0
fischer termoz SV II ecotwist PU-foam filled hole $t_{tol} = 0 - 10$ mm	100 - 150	0,001
	> 150	0
fischer termoz SV II ecotwist EPS-plug and air void $t_{tol} = 0 - 30$ mm	100 - 240	0,001
	> 240	0
fischer termoz SV II ecotwist PU-foam filled hole $t_{tol} = 0 - 30$ mm	100 - 150	0,001
	> 150	0
fischer termoz SV II ecotwist EPS-plug and air void $t_{tol} = 30 - 60$ mm	100	0,002
	120 - 240	0,001
	> 240	0
fischer termoz SV II ecotwist PU-foam filled hole $t_{tol} = 30 - 60$ mm	100	0,002
	120 - 150	0,001
	> 150	0

Table C2.2: Displacements

Base material	Minimum compressive strength f_b [N/mm ²]	Tension load N [kN]	Displacements $\delta m(N)$ [mm]
Concrete thin members $100 \text{ mm} > h \geq 40 \text{ mm} \geq \text{C20/25}$ acc. to EN 206-1 (hammer drilling)	-	0,3	< 0,3
Concrete thin members $100 \text{ mm} > h \geq 40 \text{ mm} \geq \text{C20/25}$ acc. to EN 206-1 (rotary drilling)	-	0,5	< 0,3
Concrete C16/20 - C50/60 acc. to EN 206-1 : 2000	-	0,5	< 0,3
Sand-lime solid bricks, KS acc.to EN 771-2 : 2011	20	0,5	< 0,3
	12	0,4	
Clay bricks, Mz acc. to EN 771-1:2011	12	0,4	< 0,3
Solid concrete block, Vbn acc. to EN 771-3:2011	20	0,5	< 0,3
	12	0,4	
Lightweight concrete solid blocks, Vbl acc. to EN 771-3:2011	8	0,2	< 0,2
Vertically perforated sand-lime bricks, KSL acc. to EN 771-2:2011	20	0,4	< 0,2
	12	0,25	
Vertically perforated clay bricks, Hlz acc. to EN 771-1:2011	12	0,25	< 0,3
Lightweight concrete hollow blocks, Hbl acc. to EN 771-3:2011	10	0,4	< 0,3
	8	0,3	
	6	0,25	
	4	0,2	
Lightweight concrete hollow blocks, Hbl4 acc. to EN 771-3:2011	4	0,15	< 0,4
Lightweight aggregate concrete, LAC acc. to EN 1520 :2011 / EN 771-3:2011	6	0,25	< 0,2
Autoclaved aerated concrete blocks, AAC acc. to EN 771-4:2011	4	0,15	< 0,1

fischer termoz SV II ecotwist**Performance**

Point thermal transmittance, displacements

Annex C2

Appendix 9 / 9